

New!



Features

- Freescale MPC8641 single or dual core PowerPC processor to 1.5 GHz
- Xilinx Virtex-4 FX Series FPGA
- Hosts two PMC or XMC modules
- On-board dual gigabit Ethernet interfaces
- Optional on-board 4-Gbit dual optical Fibre Channel controller
- Optional dual optical gigabit serial / Fibre Channel interface
- Up to 4 GB DDR2 SDRAM
- Two 64-bit PCI-X buses
- VME64x master/slave interface
- Optional VXS interface
- *Ruggedized and conduction-cooled versions*

General Information

The Pentek Model 4207 PowerPC™ VME/VXS I/O Processor board targets embedded applications that require high performance I/O and processing. With two PMC/XMC module sites, the 4207 offers powerful one-slot solutions with nearly unlimited high-speed connectivity.

Uniquely Designed for Connectivity

The 4207 supports numerous interfaces including VME64x, Gigabit Ethernet, RS-232 and dual 4 Gbit Fibre Channel. A unique crossbar switch architecture connects the XMC module sites, optical and VXS connectors, fibre channel interface, FPGA, and processor to high-speed gigabit serial data paths. All interfaces can be included without exceeding one VMEbus slot. Some processing-intensive applications may require two slots for optimized convection cooling.

MPC8641 AltiVec Processor

The Freescale MPC8641 utilizes the AltiVec™ engine to perform parallel processing of multiple data elements (SIMD) with 128-bit operations. The AltiVec processor

executes both fixed- and floating-point instructions. It is available with either a single or dual e600 PowerPC core with maximum clock frequency of 1.5 GHz. Built-in gigabit serial data ports provide 4X Serial RapidIO.

Zero Latency Crossbar Switch

The 4207 features a zero-latency fabric-transparent crossbar switch that bridges various board interfaces and resources via gigabit serial data paths. Programmable signal input equalization and output pre-emphasis settings enable optimization for each application.

Gigabit serial paths include links to the processor that can be used for 4X Serial RapidIO. Other gigabit paths are not restricted to any protocol, and include two 4X links to each XMC module site, two 4X links (or four 2X links) to the FPGA RocketIO ports, and another pair of 4X links to the optional P0-VXS connector. The switch also provides high-speed connectivity to the optional Fibre Channel controller and front panel optical gigabit serial interface. ➤

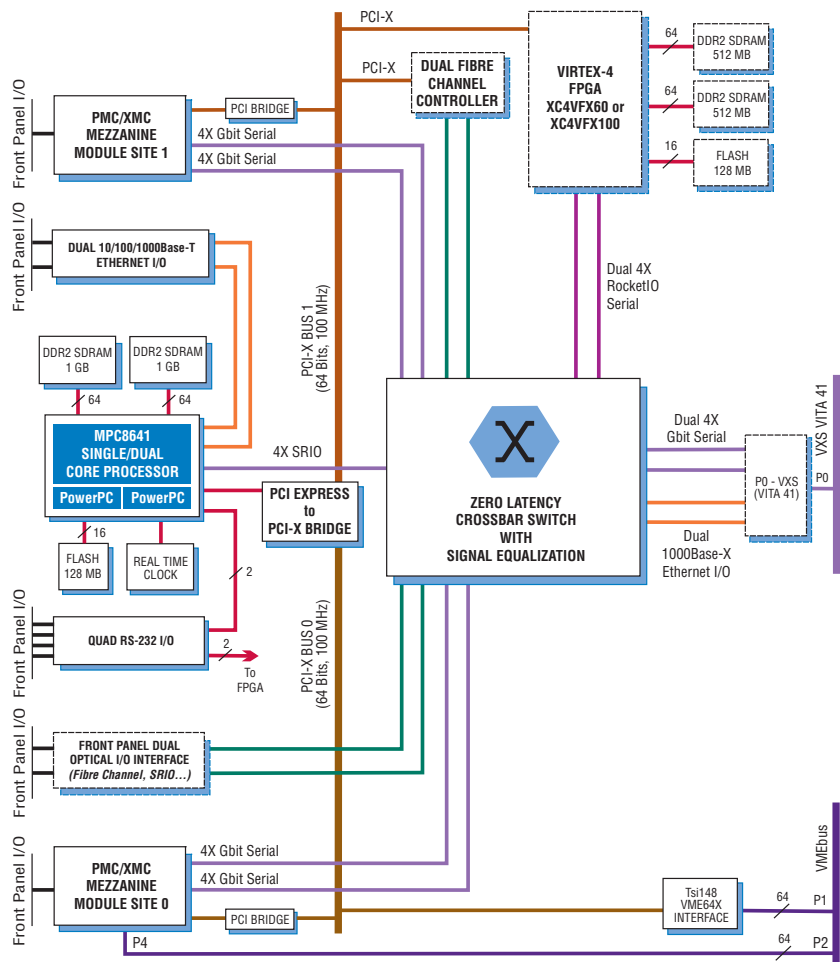

Support Software

The Model 4207 is supported by world-class software for initialization, control and optimization.

Pentek **VxWorks BSPs** provide software developers with a complete library of hardware initialization, control and application functions. Used in conjunction with Wind River's **Workbench** software development environment, it speeds application development.

Pentek **Linux BSPs and Drivers** provide software developers with a complete open-source library of hardware initialization, control and application functions to be used in a real-time Linux operating environment.

Pentek **GateFlow® Design Kits** allow the onboard FPGA to be configured by the user for implementation of custom pre-processing functions. The kit is used in conjunction with the Xilinx ISE *Foundation™* design tools.

Verari Systems' **VSI/Pro** is an implementation of VSIPL scientific and engineering functions optimized for the PowerPC.



Ordering Information

| Model | Description |
|-----------------|------------------------------------------------------------|
| 4207 | MPC8641 PowerPC I/O Processor with Virtex-4 FPGA - VME/VXS |
| Options: | |
| -001 | Front Panel Optical Connectors/Transceivers |
| -006 | Dual Fibre Channel interface, 4 Gbit/sec |
| -013 | Single core 1.33 GHz MPC8641 w/1 GB DDR2 |
| -023 | Dual core 1.33 GHz MPC8641D w/1 GB DDR2 |
| -123 | Dual core 1.33 GHz MPC8641D w/2 GB DDR2 |
| -061 | XC4VFX60-11 FPGA |
| -101 | XC4VFX100-11 FPGA |
| -360 | 1 GB FPGA DDR2 SDRAM + 128 MB FLASH |
| -361 | 2 GB FPGA DDR2 SDRAM + 128 MB FLASH |
| -5xx | VXS interface |
| -70x | Ruggedized & conduction-cooled versions |

► PMC/XMC Mezzanine Sites

Model 4207 includes two 64-bit PMC module sites which accept industry-standard modules up to 133 MHz for a wide variety of functions. The PMC modules are accessible from the MPC8641 processor and the VMEbus. A PCI bridge at each PMC site allows operation of slower 33 or 66 MHz modules while running the attached PCI-X bus at a higher speed.

The 4207 PMC sites are also equipped to accept XMC (switched-fabric PMC) modules. Gigabit switched-fabric connectors are optionally provided to support two 4X full-duplex serial ports per XMC site. Each port allows high-speed data transfer to the crossbar switch using gigabit fabrics such as Xilinx Aurora or Serial RapidIO.

FPGA Devices

The 4207 optionally includes a Xilinx Virtex-4 FX Series FPGA, the XC4VFX60 or XC4VFX100. Two 4X RocketIO ports provide a high-speed serial data path to and from the FPGA. These ports can also be configured as four 2X paths.

Unused FPGA resources are available for the user to implement custom signal-processing configurations and algorithms using Pentek's GateFlow® FPGA Design Kit and the high-performance IP Core Library.

Memory

The 4207 provides a wealth of memory resources with up to 4 Gigabytes of DDR2 SDRAM and 256 MB FLASH.

The MPC8641 PowerPC is equipped with two 64-bit banks of DDR2 SDRAM at 512 MB or 1 GB each, for up to 2 GB program and data memory. A nonvolatile 128 MB FLASH memory is also provided for initialization, self-test and boot code. 1 MB on-chip L2 cache is available per processor core.

The Virtex-4 FX Series FPGA is optionally equipped with another two 64-bit banks of DDR2 SDRAM at 512 MB or 1 GB each, and 128 MB FLASH memory.

Two PCI-X Buses

The Model 4207 architecture includes two 64-bit PCI-X buses. PCI-X Bus 0 provides access to the VMEbus and its associated PMC/XMC mezzanine site. PCI-X Bus 1 provides access to its associated PMC/XMC mezzanine site, and the optional dual Fibre Channel interfaces.

Dual Fibre Channel Interface

The 4207 features an optional dual Fibre Channel controller with optical front panel interface for high-speed data transfer to and from Fibre Channel storage devices. When installed, both optical interfaces are located on the 4207 front panel, along with the dual 10/100/1000Base-T Ethernet and the quad RS-232 interfaces. This allows Fibre Channel data transfer without sacrificing a PMC/XMC site, thus maintaining a single VMEbus slot.

VXS Interface

The 4207 provides two optional 4X full-duplex VITA-41 VXS links to the P0-VXS connector, each capable of peak rates up to 1.25 GB/sec. Each link is attached to the crossbar switch, and compatible with gigabit fabrics such as Xilinx Aurora and Serial RapidIO. The P0-VXS connector also features a dual 1000Base-X Ethernet interface per the VITA 41.6 draft standard.

Specifications

Processor Resources

Processor: Freescale MPC8641 (Single Core) or MPC8641D (Dual Core)

Processor clock: 1.33 GHz (-013 or -023)
Contact factory for options from 1 - 1.5 GHz

Level 2 cache: 1 MB for MPC8641, 2MB for MPC8641D

DDR2 SDRAM: 1 GB or 2 GB (optional, one or two 1 GB banks, each 64 bits wide)

FLASH: 128MB, 16 bits wide

Node Control: Built into MPC8641

Mezzanines

Two PMC/XMC sites

Optional FPGA

Type: Xilinx Virtex-4 Series (-11 speed) XC4VFX60 (-061) or FX100 (-101)

DDR2 SDRAM: 1 GB or 2 GB (optional, one or two 1 GB banks, each 64 bits wide)

FLASH: 128 MB, 16 bits wide (optional)

PCI-X Bus #0

Width: 64 bits, **Speed:** 100 MHz

PCI-X Bus #1

Width: 64 bits, **Speed:** 100 MHz

Global Resources

VME64x: Tundra Tsi148 master/slave, slot 1 controller, D64, A32

Serial I/O: Four RS232 front panel ports
Ethernet: Two 10/100/1000Base-T front panel ports, two 1000Base-X ports on rear P0-VXS connector

Optional Fibre Channel Controller: Dual Optical, 4 Gbit (Option -006)

Size: standard 6U VMEbus board, single slot; board 160 mm (6.3 in.) x 233.5 mm (9.2 in.), panel 0.8 in. wide